



L I N E S C A N C A M E R A S

Spark Cameras

SP-13-xxx30

SP-14-xxx30

DALSA's new small-body camera sets new standards in performance and value. Once more DALSA raises the bar by bundling an unmatched feature set into a compact package.

Features

Size

- Small form factor (50mm x 50mm x 88mm, <300g)
- 512, 1024, or 2048 x 1 resolution, 14µm square pixels

Performance

- 8-bit output from 10-bit digitizer
- 30MHz data rate, LVDS, CE-compliant
- Shock and vibration tested (MIL-STD-810E)

Advanced Functionality

- Exposure control and antiblooming
- Speed selection
- External clock detection powers down internal clock source when external clock is detected
- Test pattern generation to aid in system debug
- Free run mode—camera will operate without any external control signals
- User-selectable features:
 - 1x2 horizontal binning
 - four gain settings
 - data rate (clock divide by 1 or 2)
- Single 12V input (SP-14 only)

Description

The SP-13 and SP-14 cameras use DALSA's newest compact modular architecture. Within the camera, driver circuits provide bias voltages and clocks to the CCD image sensor, timing circuits generate internal timing, and A/D circuits process the video and digitize it for output.

Sensor

The SP-13 and SP-14 cameras use DALSA's IL-P3 line scan sensors. The sensors' photoelements have a photosensitive area of 14µm x 14µm and a center to center spacing of 14µm. Figure 4 shows a block diagram of the IL-P3 sensor. See the IL-P3 datasheet (document number 03-36-00166) for more details.



Table 1. Camera Configurations

Specification	0512	1024	2048
Pixel Pitch	[14µm x 14µm]		
Aperture	14µm x 7.2mm	14.4mm	28.8mm
Lens Mount	C-mount	C-mount	F-mount
Max. Line Rate:	50.0kHz	27.0kHz	14.0kHz
Data Format	[1x8 bits, EIA-644 (LVDS)]		
Data Rate	[30MHz]		
CE Compliance	[Yes]		
Power Supplies: SP-13	[±5V, +15V]		
SP-14	[+12V]		

Example Configuration: SP-13-01K30



Operation

Power Supplies

Cameras meet all performance specifications using standard switching supplies, although well-regulated linear supplies provide optimum performance. The SP-13 requires three input voltages (±5V, +15V), but the SP-14 requires only +12V.

Optical Interface

The SP-13 and SP-14 cameras provide an adapter for C-mount or F-mount (35mm Nikon-compatible) lenses, depending on sensor resolution. The mount threads into an opening in the camera's front plate, and is optically aligned to provide the proper distance between lens and sensor.

Figure 1. Camera Interface

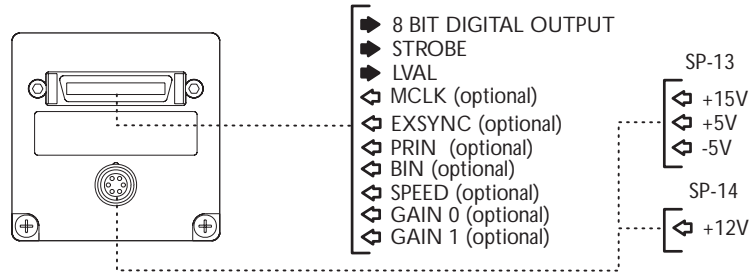

Electrical Interface

All connectors are on the camera rear plate. Spark uses a Hirose HR10A series 6-pin circular connector for power and a MDR36 (mini D-shell) for data and control signals. Data, clocking, and control signals use the EIA-644 (LVDS) standard for data transmission.

Input Control Signals

Control signals are differential, requiring complements denoted with a “B” suffix (e.g. BIN, BINB). **All inputs are optional and default to logic high.**

Most applications will use an EXSYNC input to control line rate, but the Spark can operate in “free-run mode” in which it outputs data without requiring any inputs.

Table 2. EXSYNC and PRIN

EXSYNC and PRIN are used together, as outlined below.

EXSYNC	PRIN	Camera Operation
Supplied from external source (Min 300Hz)	Disabled or unconnected (high)	Edge Mode: EXSYNC falling edge triggers line readout. Camera integrates incident light from the falling edge of EXSYNC to the next falling edge of EXSYNC.
Supplied from external source (Min 300Hz)	Enabled (low)	Level Mode: EXSYNC falling edge triggers line readout. Camera integrates incident light while EXSYNC is high (from rising edge of EXSYNC to falling edge of EXSYNC). While EXSYNC is low, the camera does not integrate incident light.
Unconnected*	Disabled or unconnected (high)	Free Run Mode: Camera operates at maximum line rate until it receives an EXSYNC edge. No exposure control.
Unconnected*	Enabled (low)	Free Run Mode: Camera operates at maximum line rate until it receives an EXSYNC edge. Each line is only exposed for ~400ns.

* Free run is disabled when the camera receives an EXSYNC edge. The camera will not free run again until it is powered off and on again.

Table 3. Control Signals

These control inputs can be used independently of each other.

MCLK	Unconnected	Internal MCLK controls pixel rate (30MHz)	
	Supplied externally	MCLK controls pixel rate (maximum 30MHz)	
SPEED	Unconnected or High	Pixel rate = MCLK rate	
	Low	Pixel rate = MCLK/2	
BIN	Unconnected or High	No binning	
	Low	Camera combines the charge collected by two horizontally adjacent pixels.	
GAIN		GAIN1 High or Unconnected	GAIN1 Low
	GAIN0 High or Unconnected	4x (default)	1x
	GAIN0 Low	2x	8x

Output Signals

These signals indicate when data is valid, allowing you to clock the data from the camera to your acquisition system:

Clocking Signal	Indicates
LVAL (high)	Outputting valid line
STROBE (rising edge)	Valid data

Digital Data

The camera digitizes to 10 bits and outputs the most significant 8 bits in LVDS format on a MDR36 connector.

After the end of each valid line, the camera outputs two isolation pixels and four test pattern pixels. These pixels alternate between 10101010 and 01010101 (eg. 170, 85, 170, 85).

Figure 2. Spark Connector Pinouts

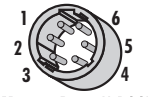
Power Connector	SP-13		SP-14		WARNING! Ensure you supply the appropriate voltage(s) for your camera model. Incorrect voltages will cause damage.	
	Pin Signal	Current	Pin Signal	Current		
 Mating Part: HIROSE HR10A-7P-6S Tolerances: ±0.25V	1	+5V	} 680mA	1	+12-15V	} 550mA
	2	+5V		2	+12-15V	
	3	+15V	80mA	3	Do not connect	
	4	-5V	80mA	4	Do not connect	
	5	GND		5	GND	
	6	GND		6	GND	
					Tolerance: ±1.0V	

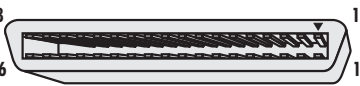
Control & Data Connector		All data and control signals use EIA-644 (LVDS) format.
Pin	Signal	
 Mating Part: 3M 10136-6000EC series Cable: 28AWG 100W shielded twisted pair		

Pin	Signal	Pin	Signal	Description	Default
1	SPEED	19	SPEEDB	Controls data rate	40MHz
2	GAIN0	20	GAIN0B	Controls gain	High
3	Future use	21	Future use	Not used: Do not connect	
4	GAIN1	22	GAIN1B	Controls gain	High
5	MCLK	23	MCLKB	Controls master clock frequency	40MHz
6	PRIN	24	PRINB	Exposure control	Disabled
7	EXSYNC	25	EXSYNCB	Controls line rate/exposure time	Free run
8	BIN	26	BINB	Controls pixel binning (summing)	Disabled
9	D7	27	D7B	} Data bits	
10	D6	28	D6B		
11	D5	29	D5B		
12	D4	30	D4B		
13	D3	31	D3B		
14	D2	32	D2B		
15	D1	33	D1B		
16	D0	34	D0B		
17	STROBE	35	STROBEB	} Outputs	
18	LVAL	36	LVALB		Pixel clock; data valid on rising edge Pixel data valid during logic high state

Notes on Operation (for full detail, see the Camera User's Manual)

1. All control signals are OPTIONAL and default to logic high state when unconnected.
2. Long unterminated cables can act as antennae, causing spurious inputs. DALSA recommends tying unused inputs to known states using differential drivers or resistive networks.
3. Max. operating temperature is 50°C ambient.
4. Free run is disabled when the camera receives an EXSYNC edge. The camera will not free run again until it is powered off and on again.

Figure 3. Mechanical Dimensions

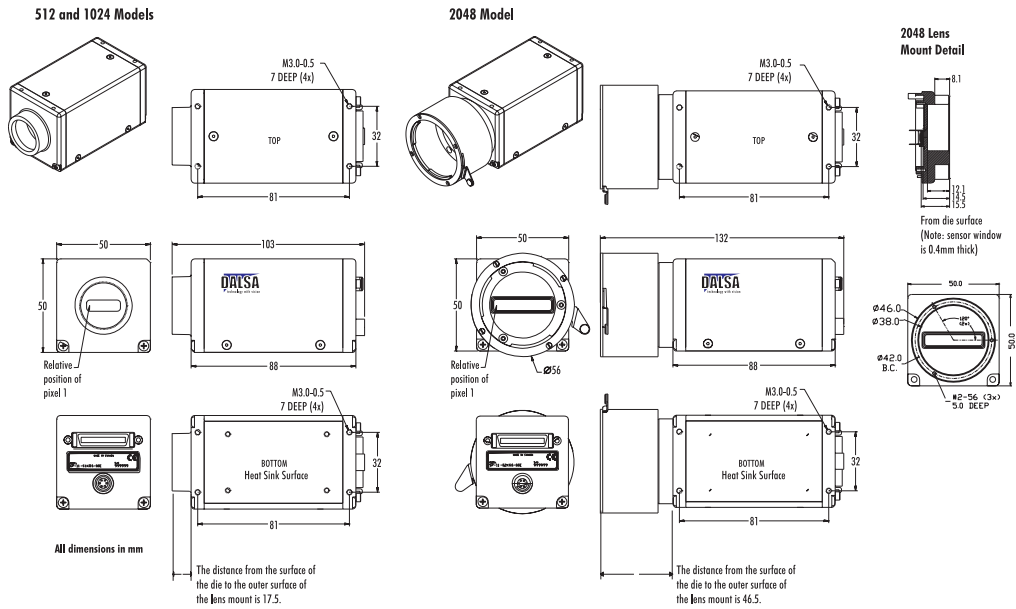

Periscope Configuration

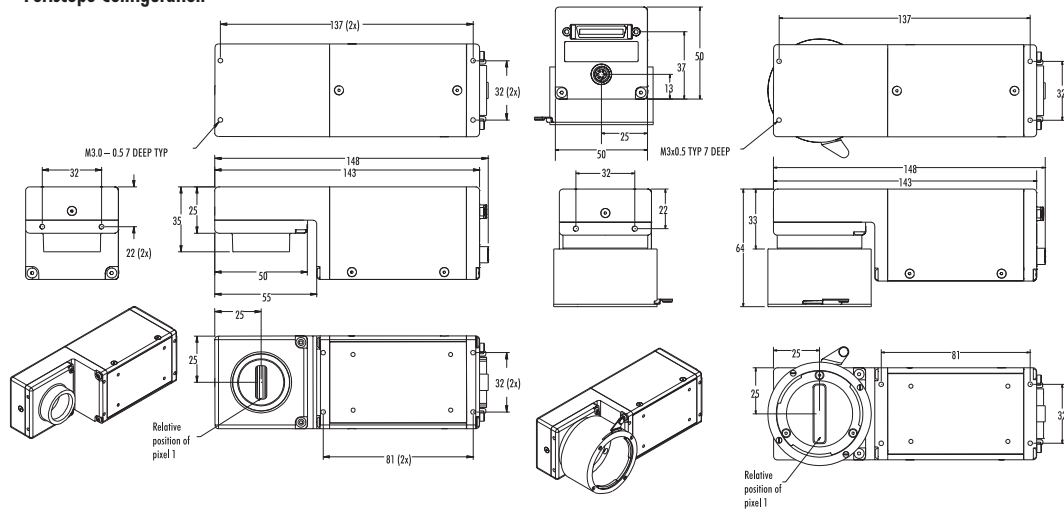

Table 4. Spark Performance Specifications

Physical Characteristics							
Size (excluding lens)		50x50x88mm					
Mass (excluding lens)	with C mount	<215g					
	with F mount	<300g					
Shock Immunity	100G	MIL-STD-810E					
Vibration Immunity	7G	MIL-STD-810E (10-2000Hz)					
Power Dissipation	SP-13-xxx30	4.5W					
	SP-14-xxx30	6W					
Regulatory Compliance	CE	EN55022:1988 class A / CISPR IEC 1000-4-2:1995, IEC 1000-4-3: 1995, IEC 1000-4-4: 1995					
Sensor Alignment	x,y	±0.005"					
	z	±0.01"					
	θ _z	0.6°					
Operating Ranges							
		Units	Min. Max.				
Data Rate		MHz	15 30				
Line Rate	2048 resolution	kHz	0.3 14				
	1024 resolution	kHz	0.3 27				
	0512 resolution	kHz	0.3 50				
Temperature		°C	0 50				
+15 Input Voltage	(SP-13 only)	Volts	14.75 15.25				
+5 Input Voltage		Volts	4.75 5.25				
-5 Input Voltage		Volts	-5.25 -4.75				
+12 Input Voltage	(SP-14 only)	Volts	11.0 16.0				
Responsivity		DN/(nJ/cm ²)	12 96				
Nominal Gain Range			1x 8x				
Calibration Conditions							
		Units	Setting Range Notes				
			Min. Max.				
Data Rate		MHz	30 30				
Line Rate		kHz	3.5 3.5 3.5				
Video Output Level		DN	245 240 250				
Light Intensity		µW/cm ²	8.75				
Responsivity		DN/(nJ/cm ²)	96 91 101				
+15 Input Voltage	(SP-13 only)	Volts	15.0 14.9 15.1				
+5 Input Voltage		Volts	5.0 4.9 5.1				
-5 Input Voltage		Volts	-5.0 -5.1 -4.9				
+12 Input Voltage	(SP-14 only)	Volts	12.0 11.9 12.1				
Ambient Temperature		°C	25 22 28				
Calibration Mode			8x Gain 4				
Electro-Optical Specifications							
		Units	Min Gain Max Gain Notes				
			Min. Typ. Max. Min. Typ. Max.				
Video Output Level		DN		255			
Photoresponse Non Uniformity (PRNU)							
PRNU, Exposure Control Disabled, Global		DN	6	12	7	16	1
PRNU, Exposure Control Enabled, Global		DN	6	12	12	22	1
PRNU, Exposure Control Disabled, Local		DN	4	9	5	11	1
PRNU, Exposure Control Enabled, Local		DN	4	9	10	16	1
Fixed Pattern Noise (FPN)							
FPN, Exposure Control Disabled, Global		DN	0.2	1.5	1.6	7	
FPN, Exposure Control Enabled, Global		DN	0.2	1.5	1.6	7	
DC Offset Exposure Control Disabled		DN	2	5 7	5	9 14	
DC Offset Exposure Control Enabled		DN	2	5 7	5	9 14	
Random Noise, pk-pk		DN		1 3		8 14	6
Random Noise, rms		DN		0.3 0.6		1.5 2	6
Dynamic Range		Ratio	410	830	120	160	6
Noise Equivalent Exposure (NEE)		pJ/cm ²		25		15.63	6
Saturation Equivalent Exposure (SEE)		nJ/cm ²		20.75		2.56	6
Supply current	+15V	mA		55 80		55 80	
	+5V (SP-13 only)	mA		480 600		480 600	3
	-5V	mA		55 80		55 80	
	+12V (SP-14 only)	mA		360 500		360 500	3

Notes to Performance Specifications:

- Performance specification values achieved under calibration conditions. Performance values also achieved over specified temperature range.
 - All measurements exclude first and last pixel.
 - No performance measurements performed for External Clock, Minimum speed with internal clock, or binning modes. Functional operation verified only.
1. Measured at 50% of Saturation Output Amplitude.
 2. Tungsten halogen light source, black body color temperature 3200K, with 750nm cutoff filter.
 3. LVDS output signals terminated.
 4. Default operating mode: Max. Speed (30MHz), High gain (8x), Exposure Control Disabled, Binning Off, Internal MCLK.
 5. Intermediate Responsivity settings available of 24 DN/(nJ/cm²) at 2x gain and 48 DN/(nJ/cm²) at 4x gain selectable through user control but not tested.
 6. Exposure Control disabled (ECD).

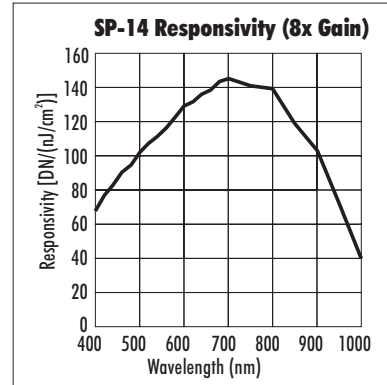
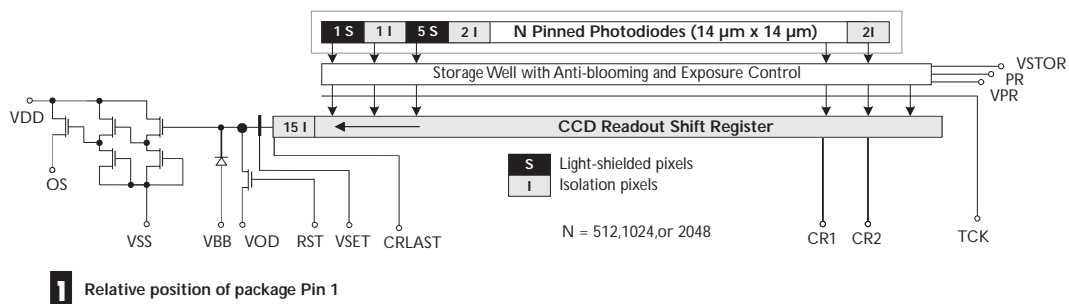

Figure 4. IL-P3 Sensor Block Diagram



ISO 9001 DALSA maintains a registered quality system meeting the ISO 9001 standard.