

DALSTAR 6M18 (Preliminary)

PRELIMINARY.

This information is
subject to change
without notice.

Ultra-high resolution...unparalleled frame rates...and truly superior image quality. The 6M18 has no equals.

With ultra-high resolution at an unparalleled frame rate, the DALSTAR 6M18 stands alone. Its high-sensitivity 12-bit images and 3k x 2k spatial resolution at up to 18 frames per second (fps) are unmatched in the industry.

The 6M18 cameras use full-frame progressive scan CCDs to simultaneously achieve outstanding resolution and gray scale characteristics. A square pixel format and 100% fill factor provide superior, quantifiable image quality even at low light levels.

The 6M18 is an outstanding performer in film scanning applications. True 12 bit performance provides up to 4096 distinct gray levels—perfect for applications with large interscene light variations. The low-noise, digitized video signal also makes the camera an excellent choice where low contrast images must be captured in challenging applications.



Features

- 18fps true 12-bit digitization
- High sensitivity with low dark current
- Progressive scan readout
- Binning
- Programmable operation (via RS232)
- 100% fill factor

Specifications

Resolution	3072 x 2048
Pixel Size	12 μ m x 12 μ m
Aperture	36.9mm x 24.6mm
Lens Mount	F-mount
Max. Line/Frame Rate	18fps
Data Rate	4x40MHz
Data Format	4x12-bit LVDS
Responsivity	19DN/(nJ/cm ²) @540nm
Dynamic Range	2800:1
Nominal Gain Range	1-10x
Size	146x92x145mm
Mass	1.3kg
Operating Temp	10-40 C
Power Supply	+5V, -5V, +15V
Power Dissipation	< 25W
Regulatory Compliance	
Example Part Number	DS-41-06M18

Applications

- Film scanning
- Large-format high-resolution high-speed imaging

Sensor

The 6M18 (Preliminary) uses a high-performance full frame CCD.

Connectors

Control	SMA coax for sync
Data	2xMDR60
Power	DB15M
Other	RJ-11F for serial link

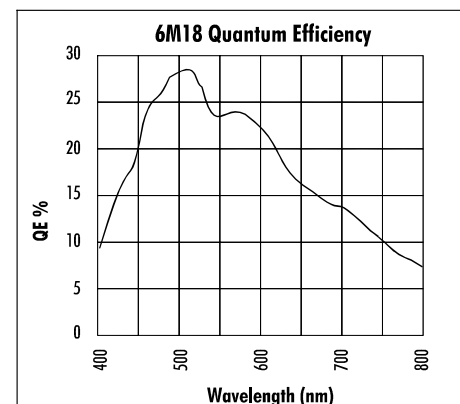

Mechanical Dimensions

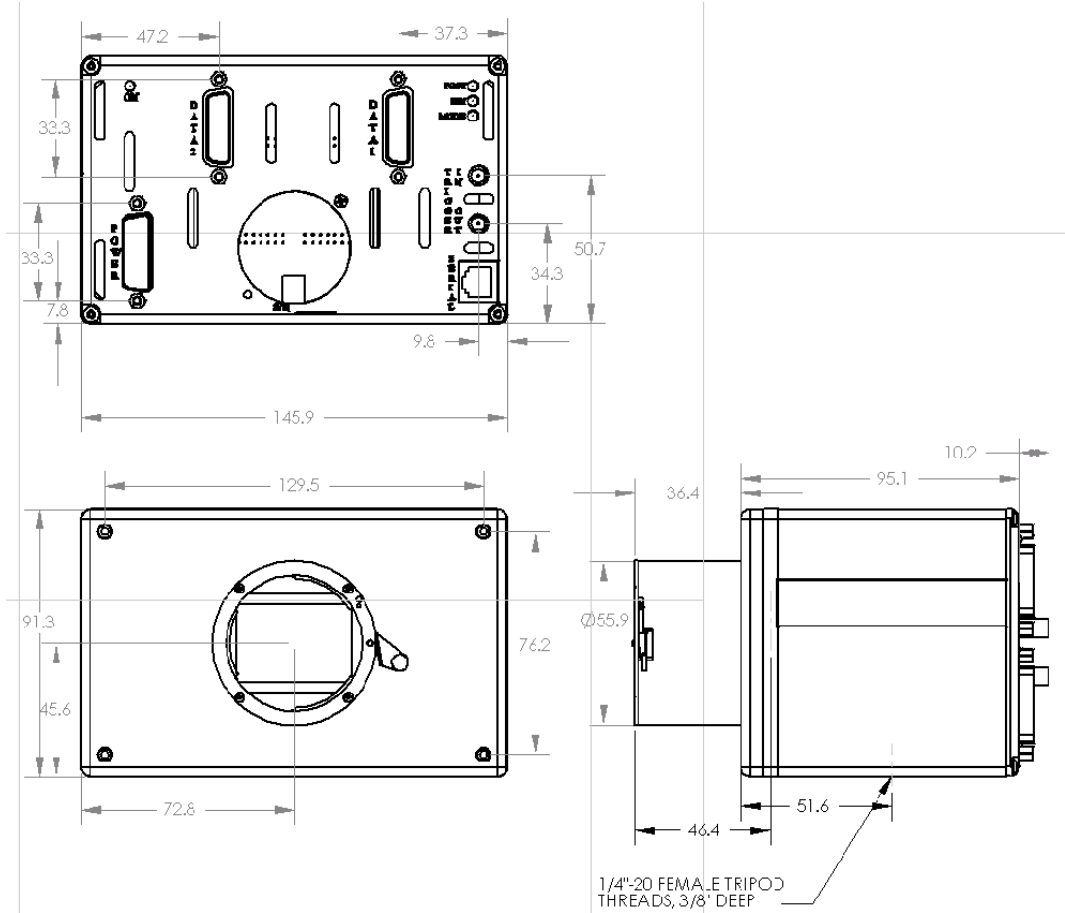

For More Information

For more detailed information on this and other products, including pinouts, timing, and signal descriptions, see the full product datasheet. Contact your local rep or visit our website at <http://vfm.dalsa.com/products>.

DALSA Worldwide Sales

605 McMurray Rd
Waterloo, ON N2V 2E9
Canada
Tel: 519 886 6000
Fax: 519 886 8023
www.dalsa.com
sales@dalsa.com

DALSA European Sales

Breslauer Str. 34
D-82194 Gröbenzell (Munich)
Germany
Tel: +49 - 8142 - 46770
Fax: +49 - 8142 - 467746
www.dalsa.com
europe@dalsa.com

DALSA Asia Pacific Sales

Space G1 Building, 4F
2-40-2 Ikebukuro
Toshima-ku, Tokyo 171-0014
Japan
+81 3 5960 6353 (phone)
+81 3 5960 6354 (fax)
www.dalsa.com
asia@dalsa.com



30-Aug-01
03-70-00120-00
www.dalsa.com

This information subject to change without notice.