

# DALSTAR 4M30 (Preliminary)

## PRELIMINARY.

This information is  
subject to change  
without notice.

### A scientific grade camera which combines high resolution, high speed and true 12 bit performance.

The DALSTAR 4M30 digital camera provides high-sensitivity 12-bit images with 2k x 2k spatial resolution at up to 30 frames per second (fps). The 4M30's full frame progressive scan CCD has a square pixel format and 100% fill factor to provide superior, quantifiable image quality even at low light levels.

True 12 bit performance provides up to 4096 distinct gray levels—perfect for applications with large interscene light variations. The low-noise, digitized video signal also makes the camera an excellent choice where low contrast images must be captured in challenging applications. Complete interface cable sets and Windows 95/98/NT control software make system set up and integration both simple and quick.



## Features

- 2048 x 2048 resolution, 30fps
- True 12-bit digitization
- High sensitivity with low dark current
- Progressive scan readout
- Programmable operation (via RS232)
- 100% fill factor

## Specifications

Resolution	2048 x 2048
Pixel Size	12 $\mu$ m x 12 $\mu$ m
Aperture	24.5mm x24.5mm
Lens Mount	F-mount
Max. Line/Frame Rate	30fps
Data Rate	4x40MHz
Data Format	4x12-bit LVDS
Responsivity	25DN/(nJ/cm <sup>2</sup> ) @540nm
Dynamic Range	3200:1
Nominal Gain Range	1-10x
Size	146x92x145mm
Mass	1.3kg
Operating Temp	10-40 C
Power Supply	+5V, -5V, +15V
Power Dissipation	30W
Regulatory Compliance	
Example Part Number	DS-41-04M30

## Applications

- Microscopy
- Laser based imaging
- Crystallography

## Sensor

The 4M30 (Preliminary) uses a high-performance full frame CCD.

## Connectors

Control	SMA coax for sync
Data	4xMDR60
Power	DB15M
Other	RJ-11F for serial link

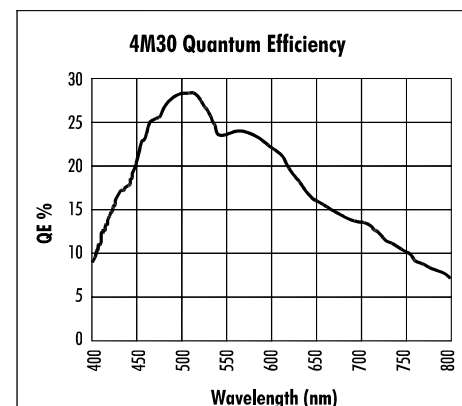

DALSTAR 4M30 (Preliminary) Area Scan Cameras

Mechanical Dimensions

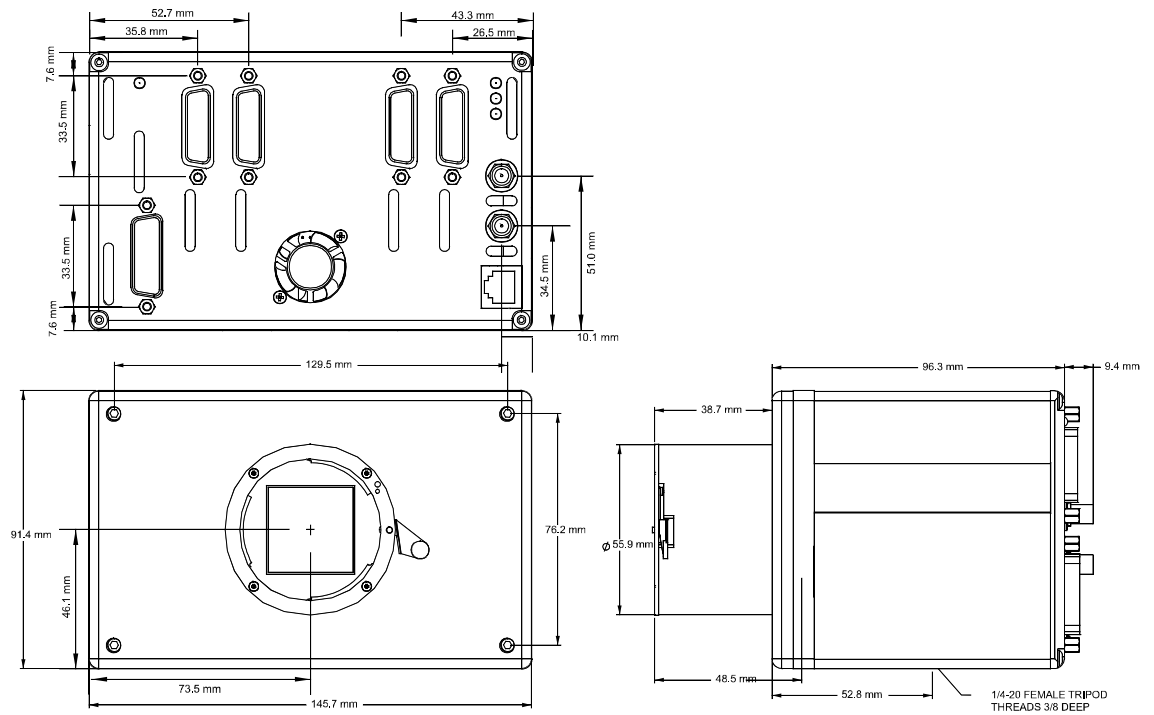

For More Information

For more detailed information on this and other products, including pinouts, timing, and signal descriptions, see the full product datasheet. Contact your local rep or visit our website at <http://vfm.dalsa.com/products>.

**DALSA Worldwide Sales**

605 McMurray Rd  
 Waterloo, ON N2V 2E9  
 Canada  
 Tel: 519 886 6000  
 Fax: 519 886 8023  
[www.dalsa.com](http://www.dalsa.com)  
[sales@dalsa.com](mailto:sales@dalsa.com)

**DALSA European Sales**

Breslauer Str. 34  
 D-82194 Gröbenzell (Munich)  
 Germany  
 Tel: +49 - 8142 - 46770  
 Fax: +49 - 8142 - 467746  
[www.dalsa.com](http://www.dalsa.com)  
[europe@dalsa.com](mailto:europe@dalsa.com)

**DALSA Asia Pacific Sales**

Space G1 Building, 4F  
 2-40-2 Ikebukuro  
 Toshima-ku, Tokyo 171-0014  
 Japan  
 +81 3 5960 6353 (phone)  
 +81 3 5960 6354 (fax)  
[www.dalsa.com](http://www.dalsa.com)  
[asia@dalsa.com](mailto:asia@dalsa.com)



30-Aug-01  
 03-70-00119-00  
[www.dalsa.com](http://www.dalsa.com)

This information subject to change without notice.